

# **7SR210** Non-Directional Relay

# **7SR220** Directional Relay

# **Installation Guide**

**(Software Version 2435H85008R7a-7a) (7SR210)**

**(Software Version 2435H85009R7a-7a) (7SR220)**

The copyright and other intellectual property rights in this document, and in any model or article produced from it (and including any registered or unregistered design rights) are the property of Siemens Protection Devices Limited. No part of this document shall be reproduced or modified or stored in another form, in any data retrieval system, without the permission of Siemens Protection Devices Limited, nor shall any model or article be reproduced from this document unless Siemens Protection Devices Limited consent.

While the information and guidance given in this document is believed to be correct, no liability shall be accepted for any loss or damage caused by any error or omission, whether such error or omission is the result of negligence or any other cause. Any and all such liability is disclaimed.

---

©2011 Siemens Protection Devices Limited

## Document Release History

This document is issue **2010/05**.

2011/05	First issue
---------	-------------

## Table of Contents

<b>Document Release History</b> .....	<b>2</b>
<b>Table of Contents</b> .....	<b>3</b>
<b>List of Figures</b> .....	<b>4</b>
<b>Section 1: Installation</b> .....	<b>5</b>
1.1 Unpacking, Storage and Handling.....	5
1.2 Recommended Mounting Position.....	5
1.3 Wiring.....	5
1.4 Earthing.....	5
1.5 Ancillary Equipment.....	5
<b>Section 2: Equipment Operating Conditions</b> .....	<b>6</b>
2.1 Current Transformer Circuits.....	6
2.2 External Resistors.....	6
2.3 Fibre Optic Communication.....	6
2.4 Front Cover.....	6
<b>Section 3: Dimensions and Panel Fixings</b> .....	<b>7</b>
3.1 Relay Dimensions and Weight.....	7
3.2 Fixings.....	8
3.2.1 Crimps.....	8
3.2.2 Panel Fixings.....	8
3.2.3 Fibre Optic Connectors.....	8
<b>Section 4: Rear Terminal Drawings</b> .....	<b>9</b>
4.1 E6 Case.....	9
4.2 E8 Case.....	11
<b>Section 5: Connection/Wiring/Diagrams</b> .....	<b>13</b>
5.1 Wiring Diagram: 7SR21 OC/EF Relay.....	13
5.2 Wiring Diagram: 7SR22 Directional OC/EF Relay.....	14
<b>Section 6: Data Comms Connections</b> .....	<b>15</b>
6.1 Standard RS485 Connections.....	15
6.2 IRIG-B Connections.....	15
6.3 Additional (Optional) Fibre Optic Connections.....	16
6.4 Additional (Optional) RS485 Connections.....	17
6.5 Additional (Optional) RS232 Connections.....	17
6.6 Additional (Optional) Ethernet Connection for IEC 61850.....	18
<b>Section 7: Connection Diagrams</b> .....	<b>19</b>
7.1 Typical Connection: 7SR22 Directional OC/EF and REF.....	19
7.2 Typical Connection: 7SR22 Directional OC/EF and NVD.....	20
7.3 Typical Connection: 7SR22 Directional OC/EF and NVD.....	21
7.4 Typical Connection: 7SR22 Directional OC/EF and NVD.....	22
7.5 Typical Connection: 7SR22 Directional OC and EF.....	23
7.6 Typical Connection: 7SR22 Connected to VTs and Capacitor Cone Unit.....	24

## List of Figures

Figure 3.1-1 Overall Dimensions (mm) and panel Drilling for Size E6 Epsilon case (Typically 4.2 kg).....	7
Figure 3.1-2 Overall Dimensions (mm) and Panel Drilling for Size E8 Epsilon Case (Typically 5.3 kg).....	7
Figure 4.1-1 E6 Standard Comms (USB Front Port, Rear RS485) (See Note 2).....	9
Figure 4.1-2 E6 Standard + Additional Comms (IRIG-B, 2 x F.O. (ST Connectors)).....	9
Figure 4.1-3 E6 Standard + Additional Comms (IRIG B + RS485) (See Note 2).....	10
Figure 4.1-4 E6 Standard + Additional Comms (IRIG B + RS232).....	10
Figure 4.2-1 E8 Standard Comms (USB Front Port, Rear RS485) (See Note 2).....	11
Figure 4.2-2 E8 Standard + Additional Comms (IRIG B, 2 x F.O. (ST Connectors)).....	11
Figure 4.3-1 E8 Standard + Additional Comms (IRIG B + RS485) (See Note 2).....	12
Figure 4.3-2 E8 Standard + Additional Comms (IRIG B + RS232).....	12
Figure 5.1-1 Connection Diagram for 7SR21 Relay.....	13
Figure 5.2-1 Connection Diagram for 7SR22 Relay.....	14
Figure 6.1-1 RS485 Data Comms Connections Between Relays.....	15
Figure 6.3-1 Data Comms to Multiple Devices Using 7SG24 and F.O. Star Network.....	16
Figure 6.3-2 Data Comms to Multiple Devices Using 7SG24 and F.O. Ring Network.....	16
Figure 6.4-1 RS485 Data Comms Connections Between Relays.....	17
Figure 6.5-1 RS232 Data Comms Pin Connections.....	17
Figure 6.5-1 Ethernet connection for IEC 61850 (star connection).....	18
Figure 6.5-1 Ethernet connection for IEC 61850 (ring connection).....	18
Figure 7.1-1 7SR22 Applied to Transformer Incomer.....	19
Figure 7.2-1 7SR22 Applied to Transformer Incomer Including HV NVD Protection.....	20
Figure 7.3-1 7SR22 Applied to Feeder Including NVD Protection.....	21
Figure 7.4-1 7SR22 Applied to Feeder.....	22
Figure 7.5-1 7SR22 Applied to Feeder - No Zero Sequence Voltage Source.....	23
Figure 7.6-1 7SR22 Applied to Feeder with Capacitor Cones Fitted.....	24

# Section 1: Installation

## 1.1 Unpacking, Storage and Handling

On receipt remove the relay from the container in which it was received and inspect it for obvious damage. It is recommended that the relay not be removed from its case.

If damage has been sustained a claim should be immediately be made against the carrier, also inform Siemens Protection Devices Limited, and to the nearest Siemens agent, using the Defect Report Form in the Maintenance section of this manual.

When not required for immediate use, the relay should be returned to its original carton and stored in a clean, dry place.

The relay contains static sensitive devices, which are susceptible to damage due to static discharge. The relay's electronic circuits are protected from damage by static discharge when the relay is housed in its case.

There can be no requirement to disassemble any relay, since there are no user serviceable parts in the relay. If any modules have been tampered with, then the guarantee will be invalidated. Siemens Protection Devices Limited reserves the right to charge for any subsequent repairs.

## 1.2 Recommended Mounting Position

The relay uses a liquid crystal display (LCD) which is used in the programming and for operation. The LCD has a vertical viewing angle of  $\pm 30^\circ$  and is back-lit. However, the best viewing position is at eye level, and this is particularly important given its control features.

The relay should be mounted on the circuit breaker (or protection panel) to allow the operator the best access to the relay functions

## 1.3 Wiring

The product should be wired according to the scheme requirements, with reference to the appropriate wiring diagram. Refer to the appropriate Diagrams and Parameters document for a cross reference of wiring diagrams and models.

## 1.4 Earthing

Terminal 28 of the PSU (Power Supply Unit) should be solidly earthed by a direct connection to the panel earth. The Relay case earth stud connection should be connected to terminal 28 of the PSU.

It is normal practice to additionally 'daisy chain' together the case (safety) earths of all the Relays installed in a panel to prevent earth current loops posing a risk to personnel.

## 1.5 Ancillary Equipment

The relay can be interrogated locally or remotely. For local interrogation a portable PC with suitable version of MS Windows (2000 SP4 or XP SP2) and Reydisp Evolution™ s/w (Latest Version available 32 bit) using USB port situated on front of the relay.

## Section 2: Equipment Operating Conditions

### 2.1 Current Transformer Circuits



The secondary circuit of a live CT must not be open circuited. Non-observance of this precaution can result in injury to personnel or damage to equipment.



### 2.2 External Resistors

Where external resistors are fitted to relays, these may present a danger of electric shock or burns, if touched.



### 2.3 Fibre Optic Communication

Where fibre optic communication devices are fitted, these should not be viewed directly. Optical power meters should be used to determine the operation or signal level of the device.



### 2.4 Front Cover

The front cover provides additional securing of the relay element within the case. The relay cover should be in place during normal operating conditions.

## Section 3: Dimensions and Panel Fixings

### 3.1 Relay Dimensions and Weight

Relays are supplied in the modular size E6 or E8

The following drawings are available which give panel cut-out and mounting details.

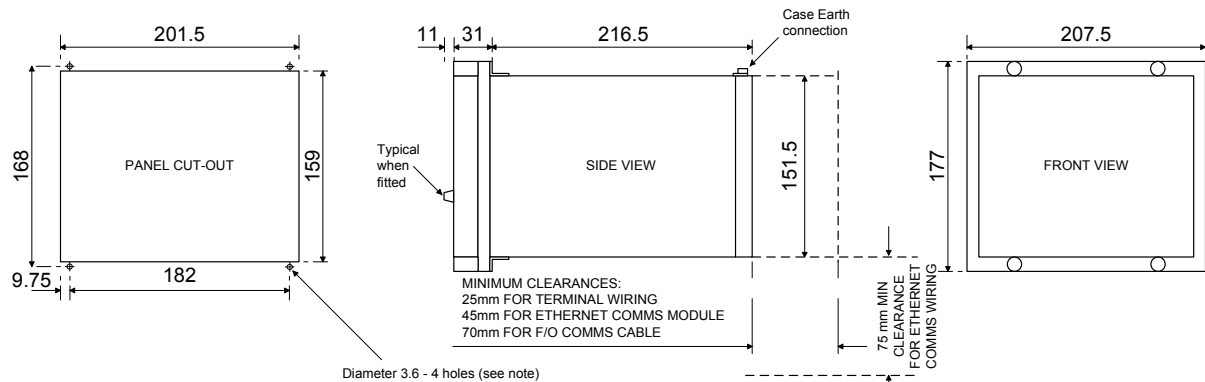

NOTE:  
THE 3.6 HOLES ARE FOR M4 THREAD FORMING (TRILOBULAR) SCREWS. THESE ARE SUPPLIED AS STANDARD AND ARE SUITABLE FOR USE IN FERROUS / ALUMINIUM PANELS 1.6mm THICK AND ABOVE. FOR OTHER PANELS, HOLES TO BE M4 CLEARANCE (TYPICALLY 4.5 DIAMETER) AND RELAYS MOUNTED USING M4 MACHINE SCREWS, NUTS AND LOCKWASHERS (SUPPLIED IN PANEL FIXING KIT).

THE RETAINING SCREW AT THE REAR OF THE CASE FOR THE ETHERNET VARIANT MUST BE FITTED FOR THE DEVICE TO COMPLY WITH PERFORMANCE CLAIMS.

**Figure 3.1-1 Overall Dimensions (mm) and panel Drilling for Size E6 Epsilon case (Typically 4.2 kg)**

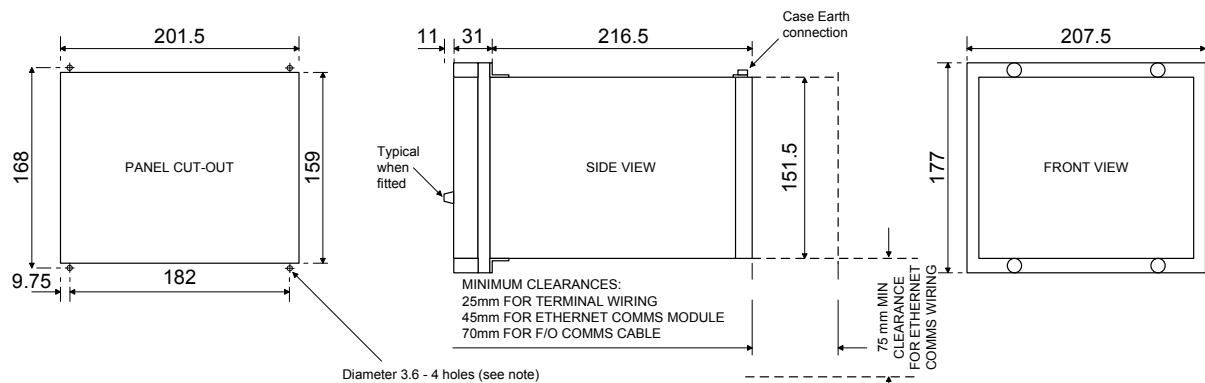

NOTE:  
THE 3.6 HOLES ARE FOR M4 THREAD FORMING (TRILOBULAR) SCREWS. THESE ARE SUPPLIED AS STANDARD AND ARE SUITABLE FOR USE IN FERROUS / ALUMINIUM PANELS 1.6mm THICK AND ABOVE. FOR OTHER PANELS, HOLES TO BE M4 CLEARANCE (TYPICALLY 4.5 DIAMETER) AND RELAYS MOUNTED USING M4 MACHINE SCREWS, NUTS AND LOCKWASHERS (SUPPLIED IN PANEL FIXING KIT).

THE RETAINING SCREW AT THE REAR OF THE CASE FOR THE ETHERNET VARIANT MUST BE FITTED FOR THE DEVICE TO COMPLY WITH PERFORMANCE CLAIMS.

**Figure 3.1-2 Overall Dimensions (mm) and Panel Drilling for Size E8 Epsilon Case (Typically 5.3 kg)**

Hardware Model	Net Weight kg
7SR2102	3.3
7SR2103	4.6
7SR2104	4.8
7SR2202	4.8
7SR2203	4.9
7SR2204	5.0

**NB: If supplied with communication interface devices please add an additional 0.165 kg**

## 3.2 Fixings

### 3.2.1 Crimps

Ring tongued crimps with 90° bend are recommended.

### 3.2.2 Panel Fixings

Typical mounting screw kit per Relay)

Consists of 4 off M4x10mm Screws

4 off M4 Nuts

4 off M4 Lock Washer

Typical rear terminal block fixing kit (1kit per terminal block fitted to relay) Consists of:

28 x M4, 8mm Screws

28 x M4 Lock Washer

### 3.2.3 Fibre Optic Connectors

The relay has Fibre-Optic ST™ (BFOC/2.5) bayonet connectors fitted when specified.



## Section 4: Rear Terminal Drawings

### 4.1 E6 Case

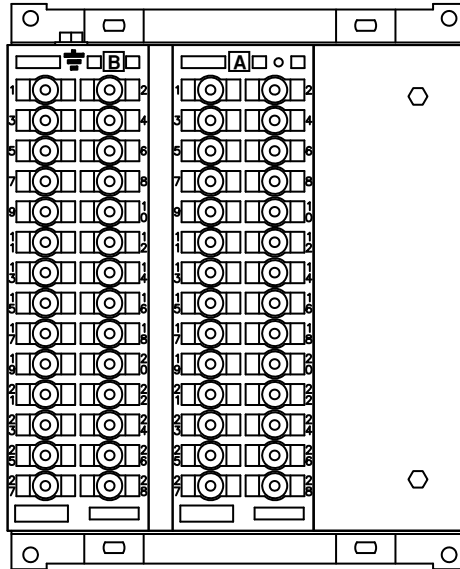

Figure 4.1-1 E6 Standard Comms (USB Front Port, Rear RS485) (See Note 2)

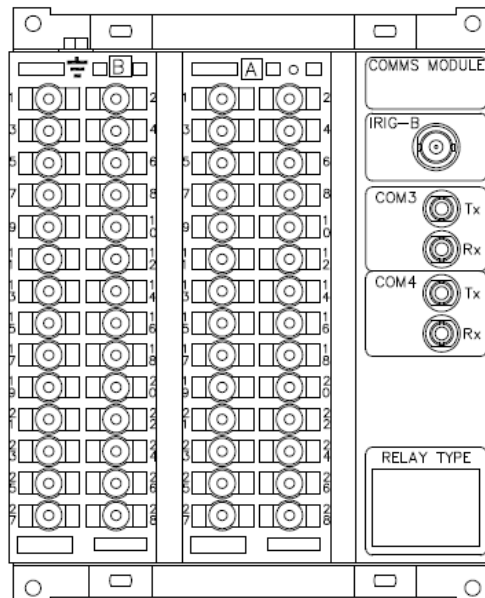

Figure 4.1-2 E6 Standard + Additional Comms (IRIG-B, 2 x F.O. (ST Connectors))

#### Notes

- 1) Recommended terminations are pre-insulated & must be crimped using approved tooling.
- 2) RS485 (block "B" terms 14, 16, 18, 20) connections to this communication facility is by screened, twisted pair cable. On site when wiring other facilities ensure that these terminals are not obscured by other wiring runs. Cable should be RS485 compliant.

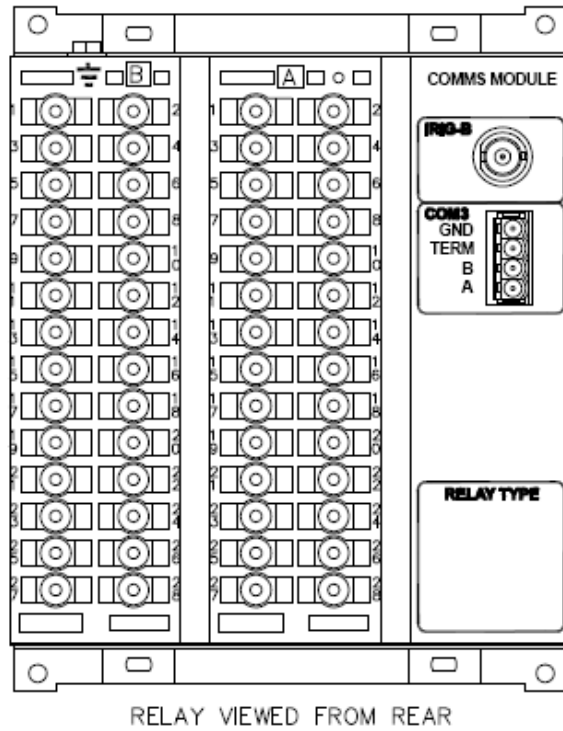

Figure 4.1-3 E6 Standard + Additional Comms (IRIG B + RS485) (See Note 2)

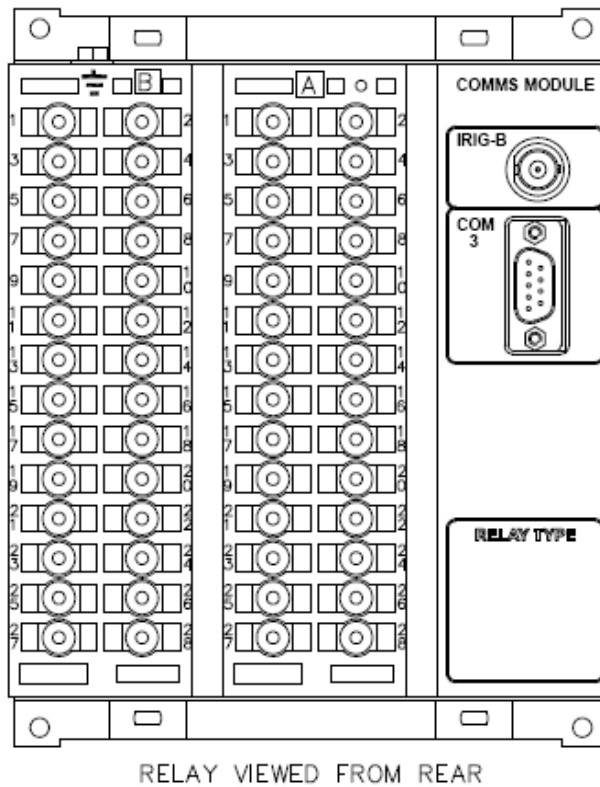

Figure 4.1-4 E6 Standard + Additional Comms (IRIG B + RS232)

## 4.2 E8 Case

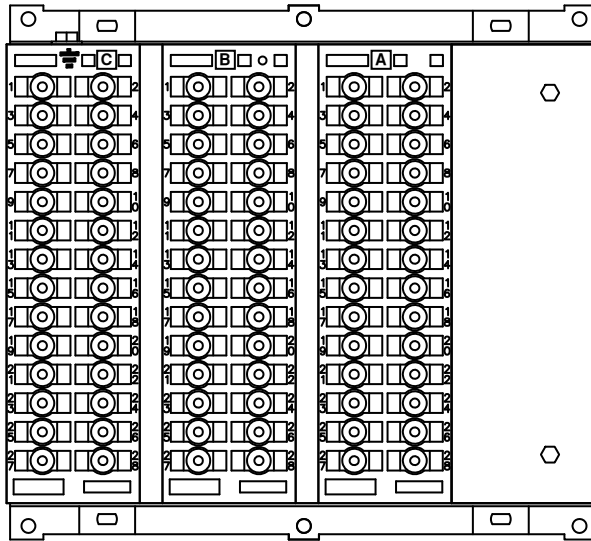

Figure 4.2-1 E8 Standard Comms (USB Front Port, Rear RS485) (See Note 2)

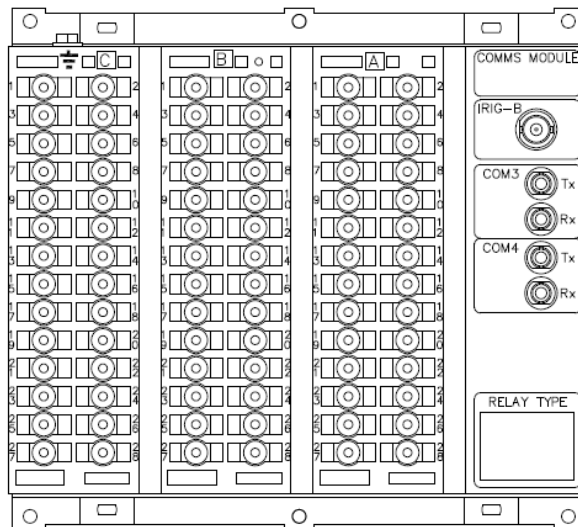
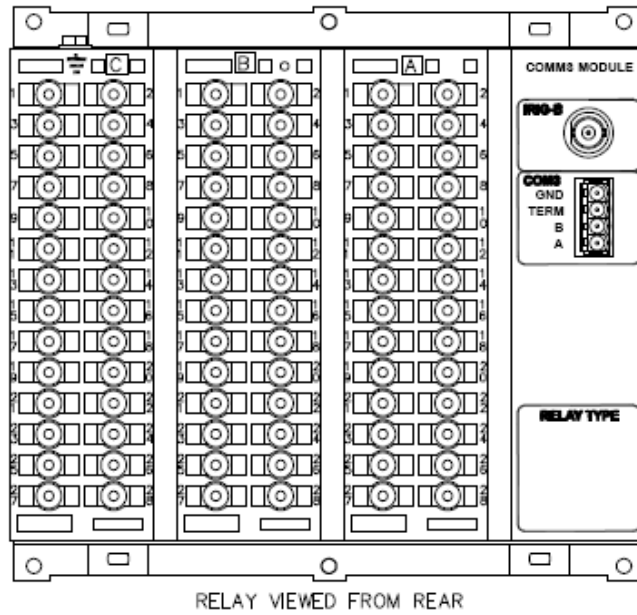

Figure 4.2-2 E8 Standard + Additional Comms (IRIG B, 2 x F.O. (ST Connectors))

### Notes

- 1) Recommended terminations are pre-insulated & must be crimped using approved tooling.
- 2) RS485 (block "B" terms 14, 16, 18, 20) connections to this communication facility is by screened, twisted pair cable. On site when wiring other facilities ensure that these terminals are not obscured by other wiring runs. Cable should be RS485 compliant.



**Figure 4.2-3 E8 Standard + Additional Comms (IRIG B + RS485) (See Note 2)**

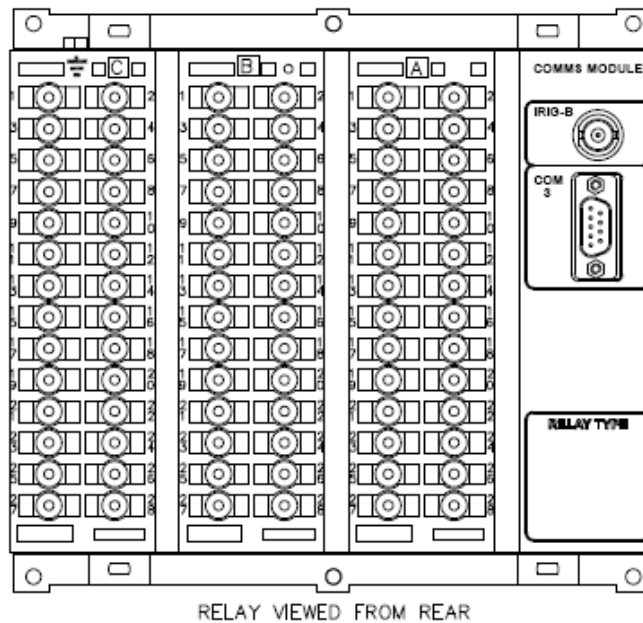

**Figure 4.2-4 E8 Standard + Additional Comms (IRIG B + RS232)**

**Notes**

- 1) Recommended terminations are pre-insulated & must be crimped using approved tooling.
- 2) RS485 (block "B" terms 14, 16, 18, 20) connections to this communication facility is by screened, twisted pair cable. On site when wiring other facilities ensure that these terminals are not obscured by other wiring runs. Cable should be RS485 compliant.

# Section 5: Connection/Wiring/Diagrams

## 5.1 Wiring Diagram: 7SR21 OC/EF Relay

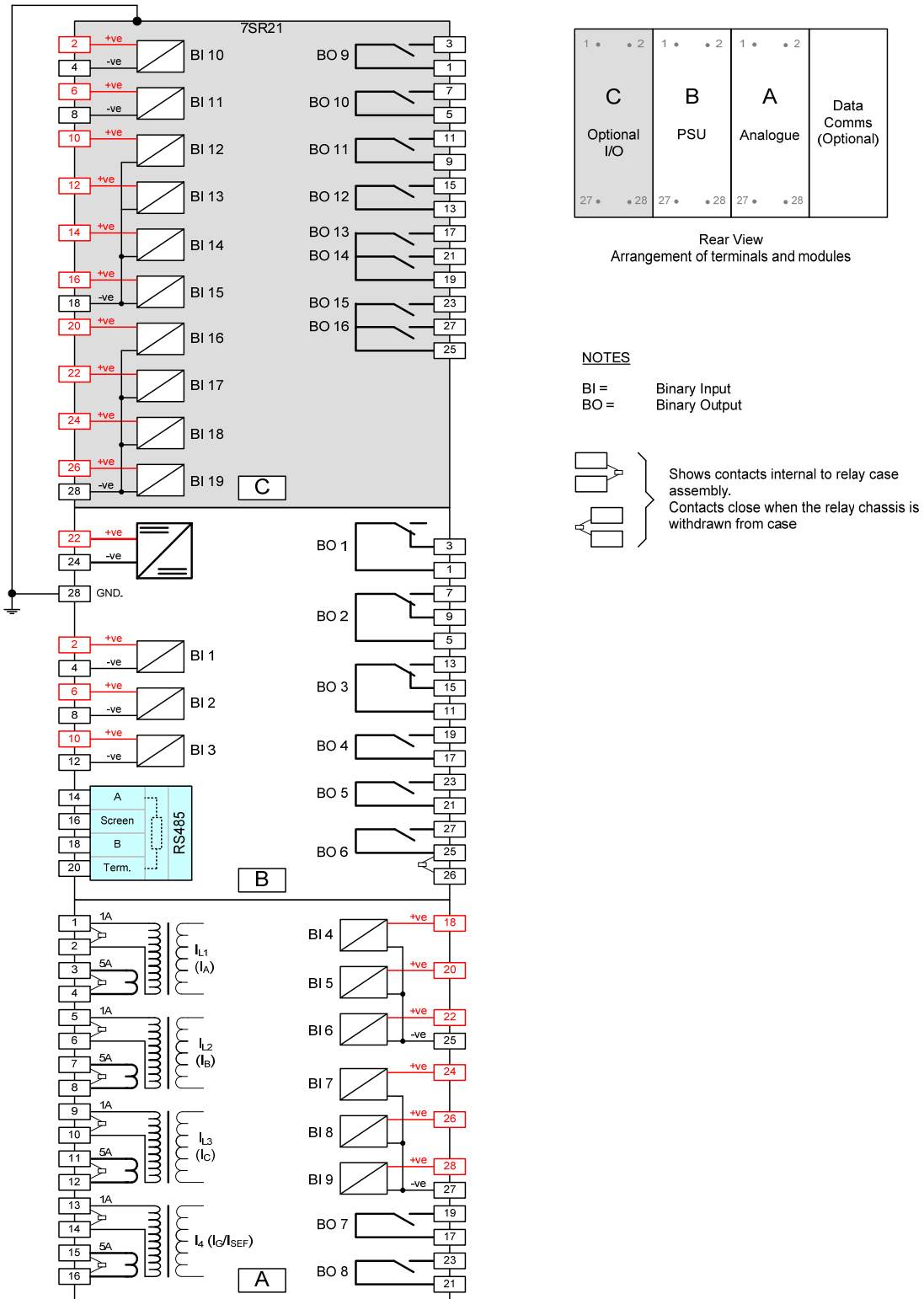

Figure 5.1-1 Connection Diagram for 7SR21 Relay

## 5.2 Wiring Diagram: 7SR22 Directional OC/EF Relay

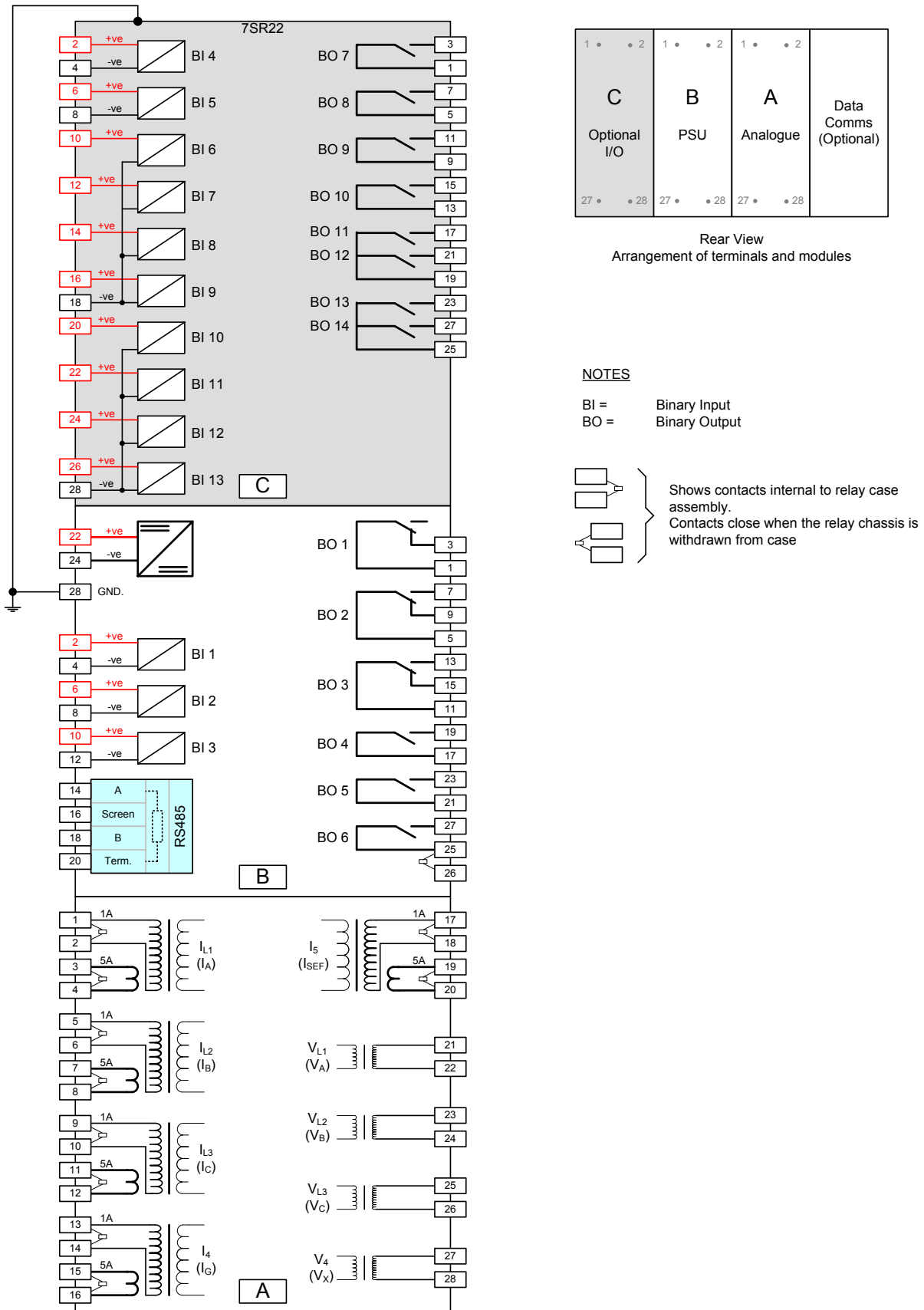

Figure 5.2-1 Connection Diagram for 7SR22 Relay

## Section 6: Data Comms Connections

### 6.1 Standard RS485 Connections

The standard RS485 communication port is located on terminal block 2 at the rear of the relay and can be connected using a suitable RS485 120Ω screened twisted pair cable.

The RS485 electrical connection can be used in a single or multi-drop configuration. The RS485 master must support and use the Auto Device Enable (ADE) feature.

The last device in the connection must be terminated correctly in accordance with the master driving the connection. A terminating resistor is fitted in each relay, when required this is connected in circuit using an external wire loop between terminals 18 and 20 of the power supply module.

Up to 64 relays can be connected to the RS485 bus.

The RS485 data communications link with a particular relay will be broken if the relay element is withdrawn from the case, all other relays will still communicate.

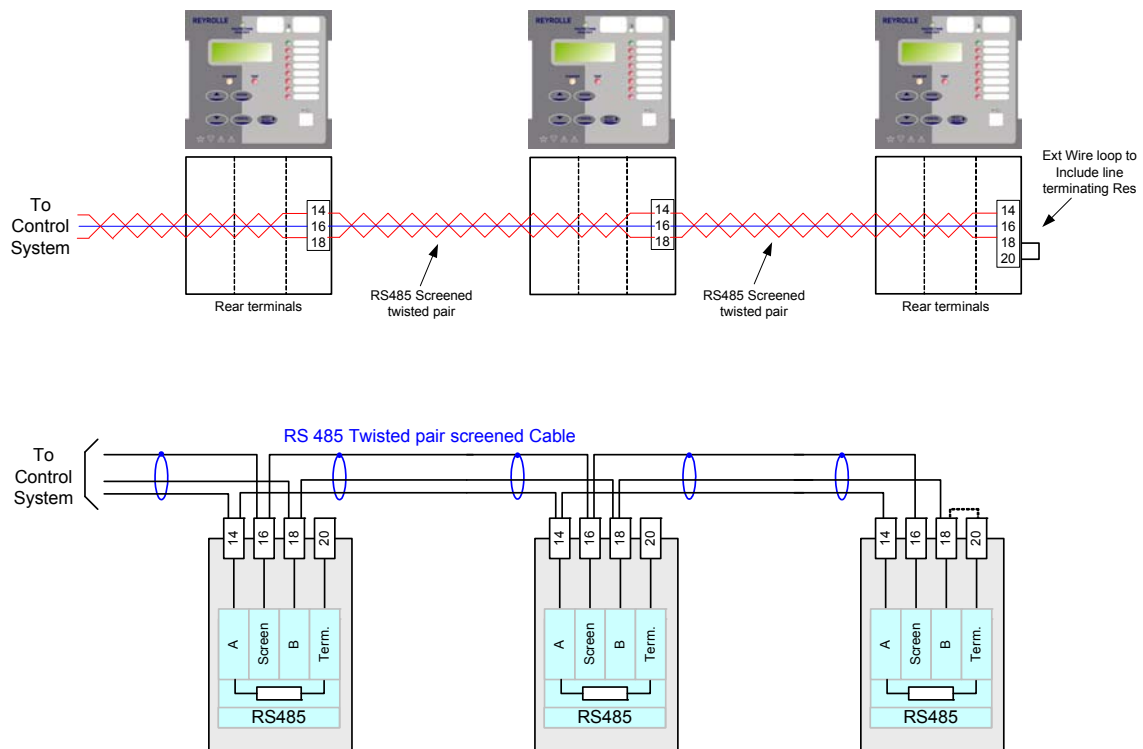

Figure 6.1-1 RS485 Data Comms Connections Between Relays

### 6.2 IRIG-B Connections

A BNC plug is provided on the optional additional communication interface modules to connect a co-axial cable carrying IRIG-B time synchronisation signals. Ensure that the stub length is minimised by connecting the tee-connector directly to the rear of the relay. A suitable co-axial cable would be type RG 58 50ohms.

### 6.3 Additional (Optional) Fibre Optic Connections

Rear Com ports 3 and 4 comprise Fibre–Optic ST™ (BFOC/2.5) bayonet connectors-4 per product. 62.5 / 125µm glass fibre is recommended for all distances.

When installing fibre, ensure that the fibres' bend radii comply with the recommended minimum for the fibre used- typically 50mm is acceptable.

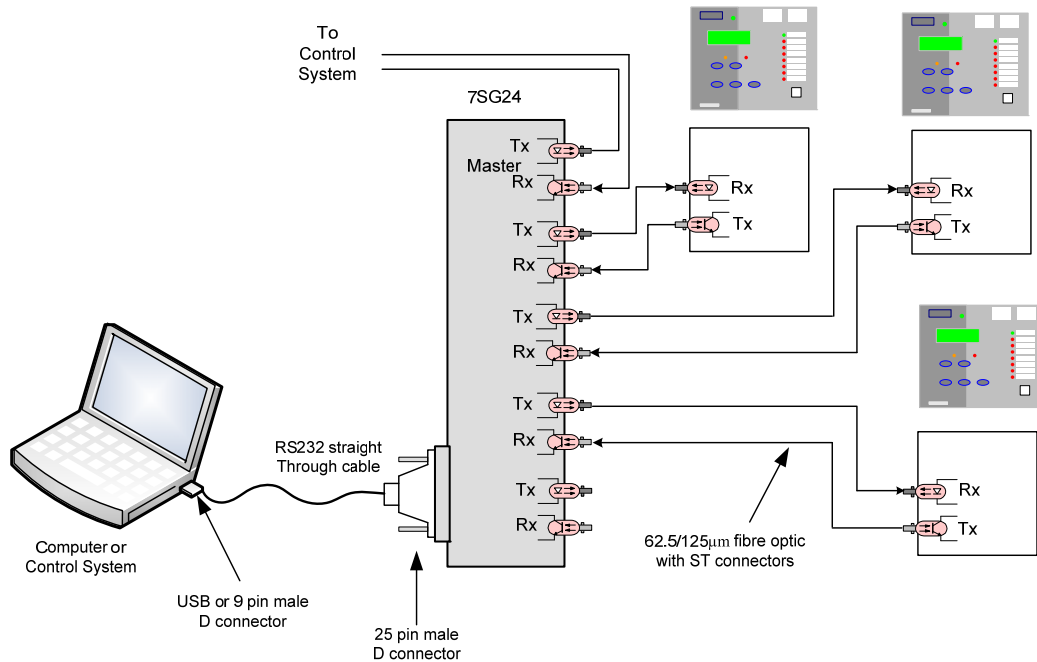

Figure 6.3-1 Data Comms to Multiple Devices Using 7SG24 and F.O. Star Network

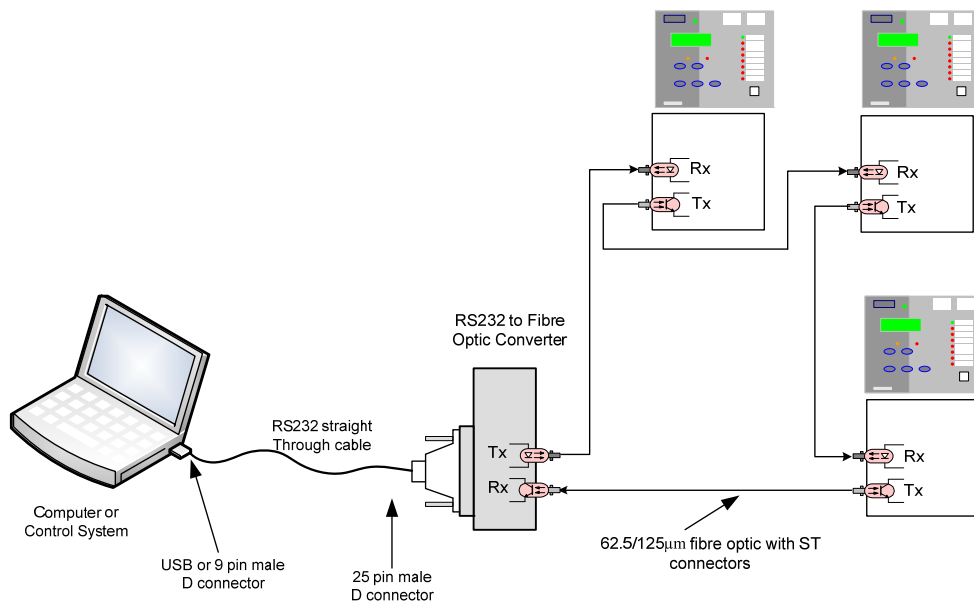

Figure 6.3-2 Data Comms to Multiple Devices Using 7SG24 and F.O. Ring Network

The F.O. data communications link with a particular relay will be broken if the relay element is withdrawn from the case, all other relays will still communicate.



## 6.4 Additional (Optional) RS485 Connections

The additional (optional) RS485 communication port is located at the rear of the relay and can be connected using a suitable RS485 120 ohm screened twisted pair cable.

The RS485 electrical connection can be used in a single or multi-drop configuration. The RS485 master must support and use the Auto Device Enable (ADE) feature.

The last device in the connection must be terminated correctly in accordance with the master device driving the connection. The relays are fitted with an internal terminating resistor which can be connected between the A and B by fitting an external wire loop between terminals 18 and 20 on the power supply module.

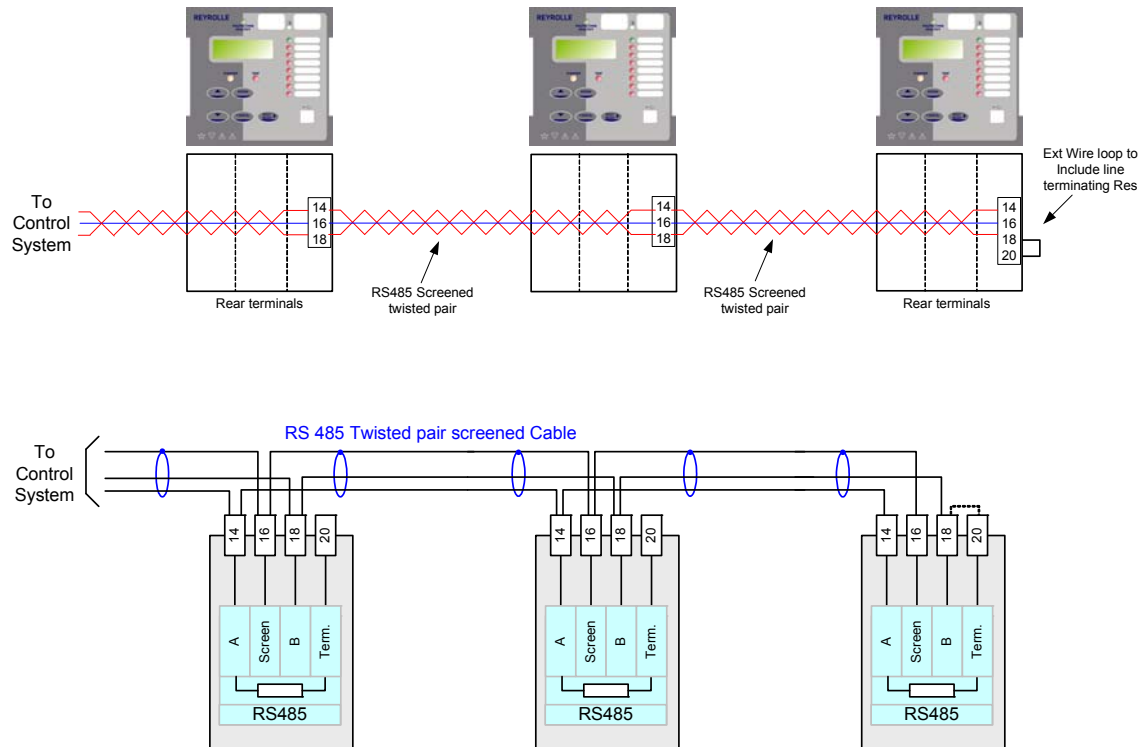

Figure 6.4-1 RS485 Data Comms Connections Between Relays

## 6.5 Additional (Optional) RS232 Connections

The additional (optional) RS232 (9 pin plug) (DTE) communication port is located at the rear of the relay and can be connected using a suitable RS232 cable.

Where there is a requirement for multi-drop RS232 connection, a suitable device to facilitate this should be obtained.

Pin	Relay Function
1	Not Connected
2	Receive Data (RXD)
3	Transmit Data (TXD)
4	Input Supply +5 V
5	Signal Ground (GND)
6	Input Supply +5 V
7	Linked to 8 (volts free)
8	Linked to 7 (volts free)
9	Output Supply +5 V 50mA

Figure 6.5-1 RS232 Data Comms Pin Connections

## 6.6 Additional (Optional) Ethernet Connection for IEC 61850

Rear Ethernet Comms port Ch 1 and Ch 2 comprises Fibre–Optic ST™ (BFOC/2.5) bayonet connectors or electrical RJ45 connectors.

When installing fibre, ensure that the fibres' bend radii comply with the recommended minimum for the fibre used—typically 50mm is acceptable, 62.5 / 125µm glass fibre is recommended for all distances.

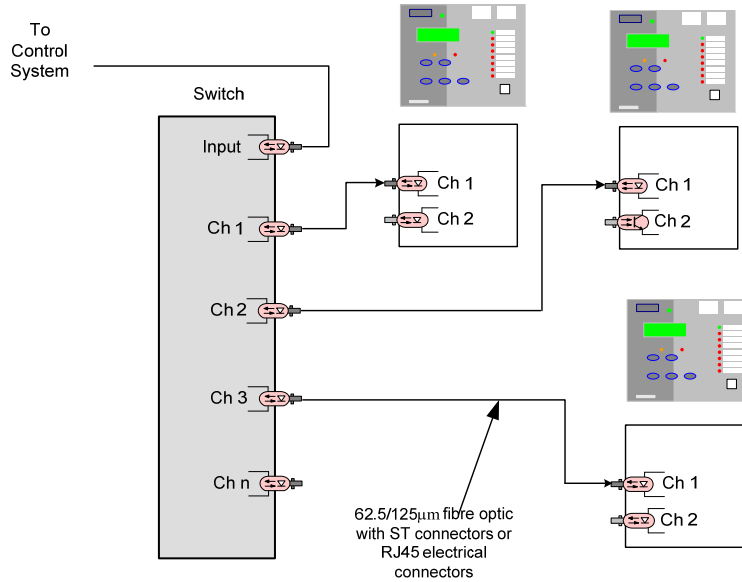

Figure 6.6-1 Ethernet connection for IEC 61850 (star connection)

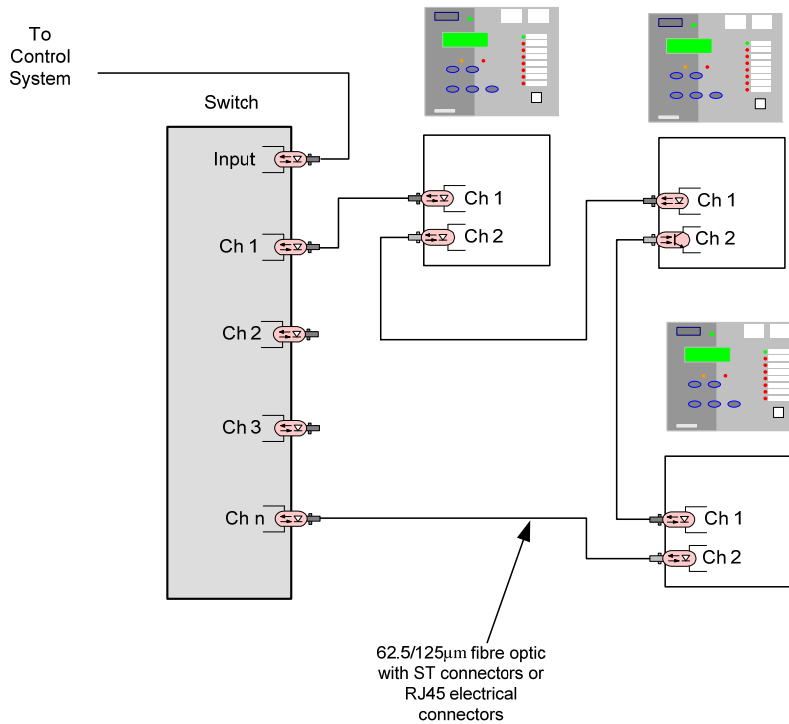

Figure 6.6-2 Ethernet connection for IEC 61850 (ring connection)

## Section 7: Connection Diagrams

### 7.1 Typical Connection: 7SR22 Directional OC/EF and REF

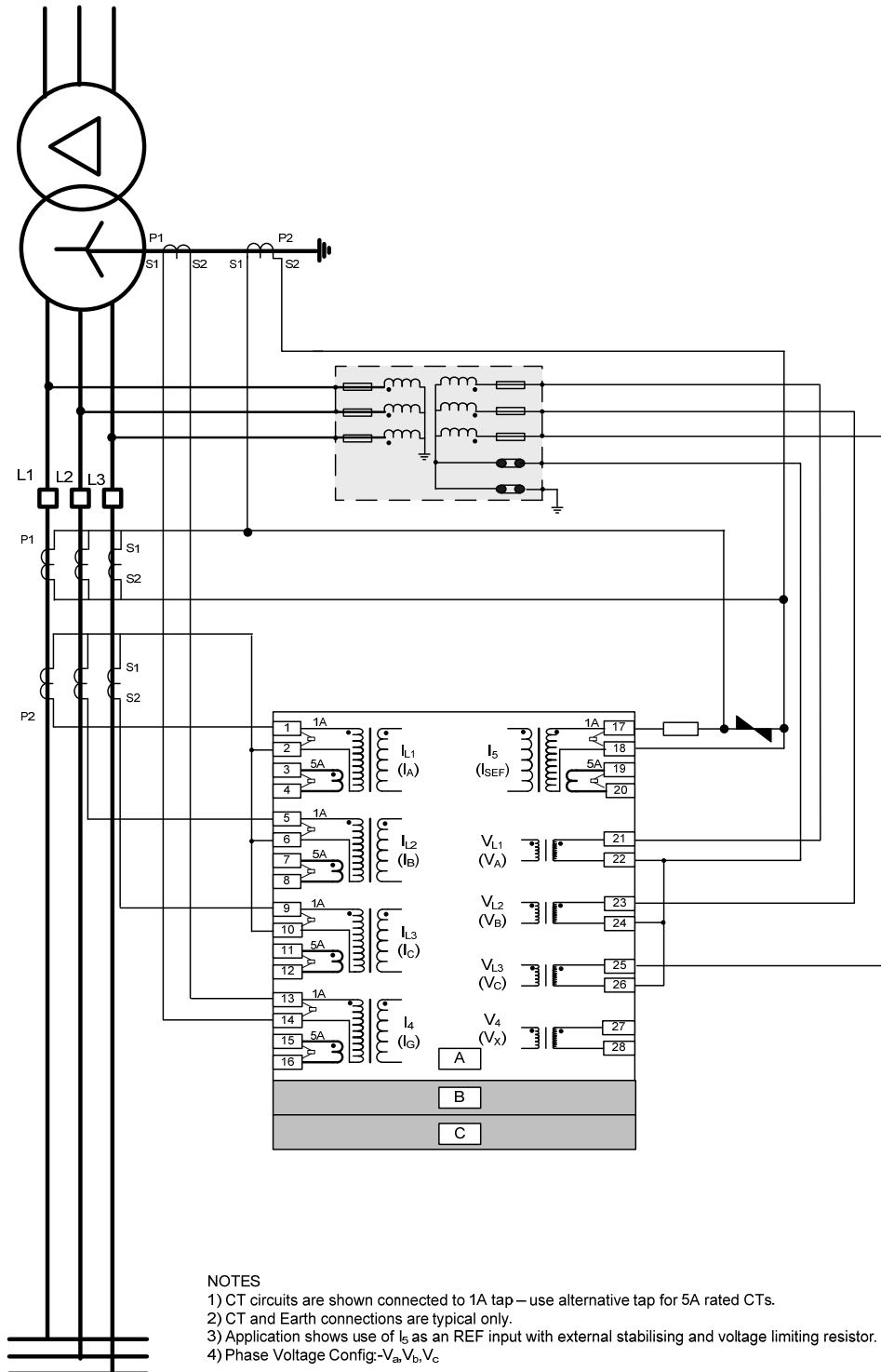

Figure 7.1-1 7SR22 Applied to Transformer Incomer

## 7.2 Typical Connection: 7SR22 Directional OC/EF and NVD

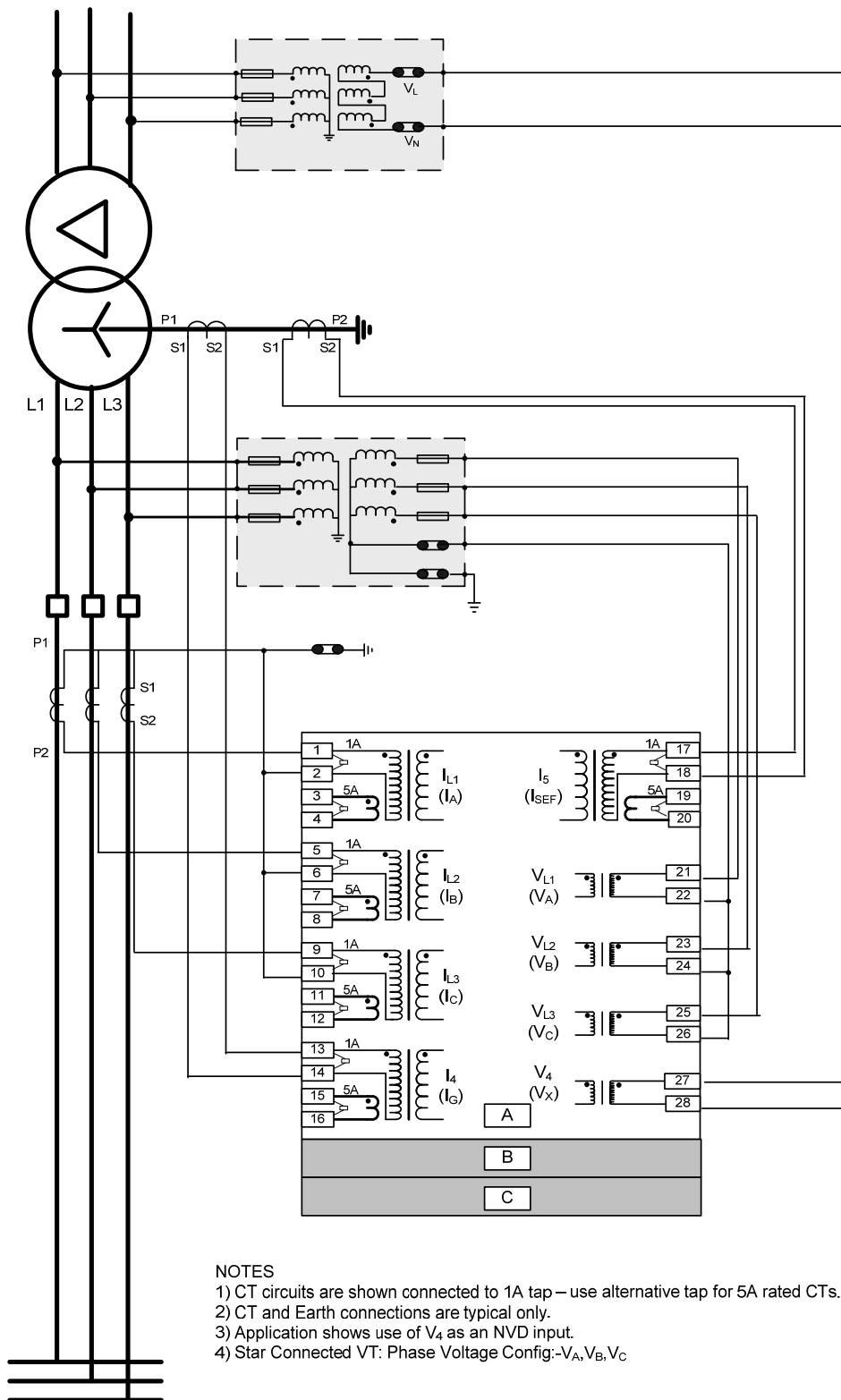

Figure 7.2-1 7SR22 Applied to Transformer In-come Including HV NVD Protection

### 7.3 Typical Connection: 7SR22 Directional OC/EF and NVD

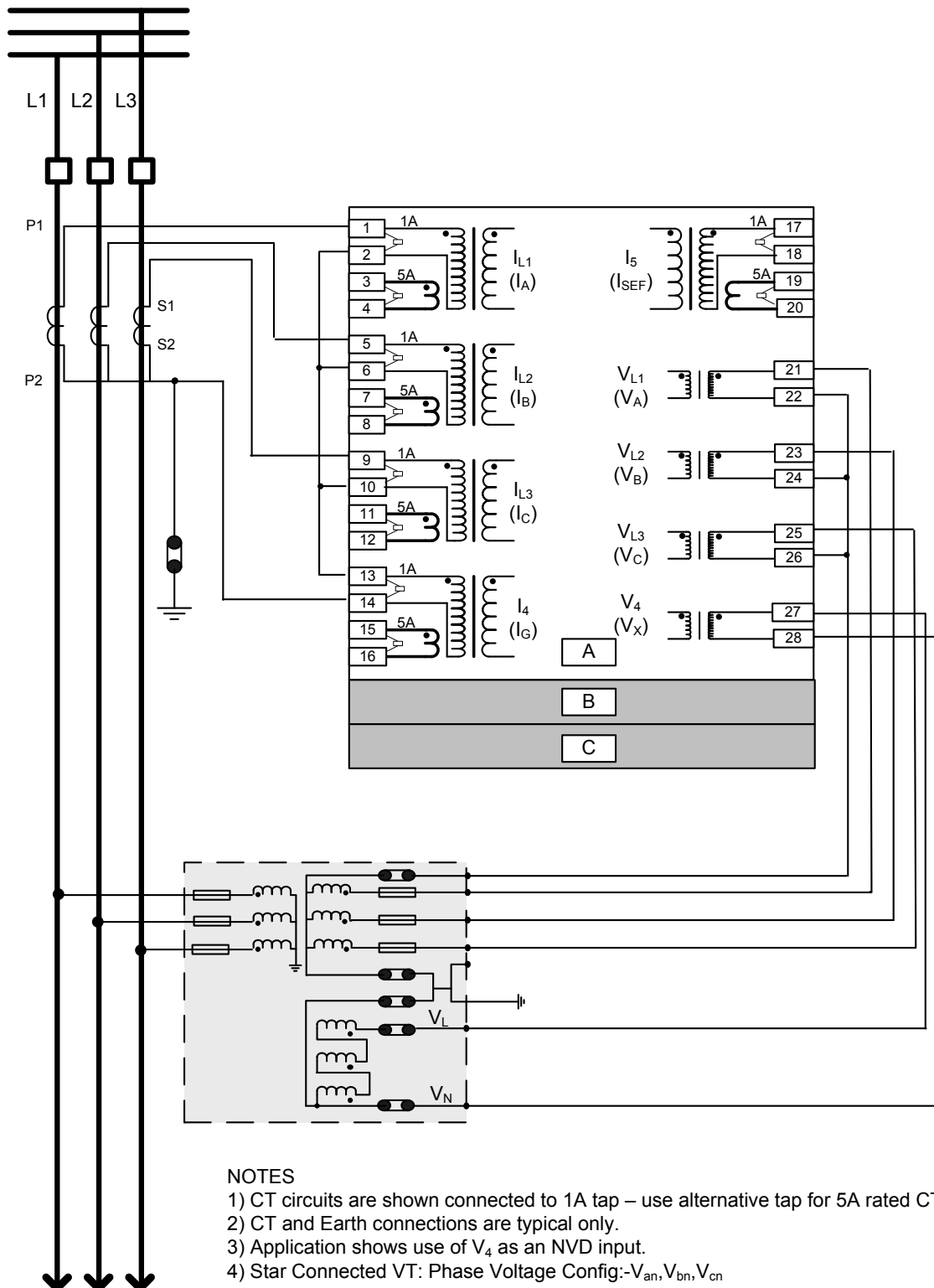
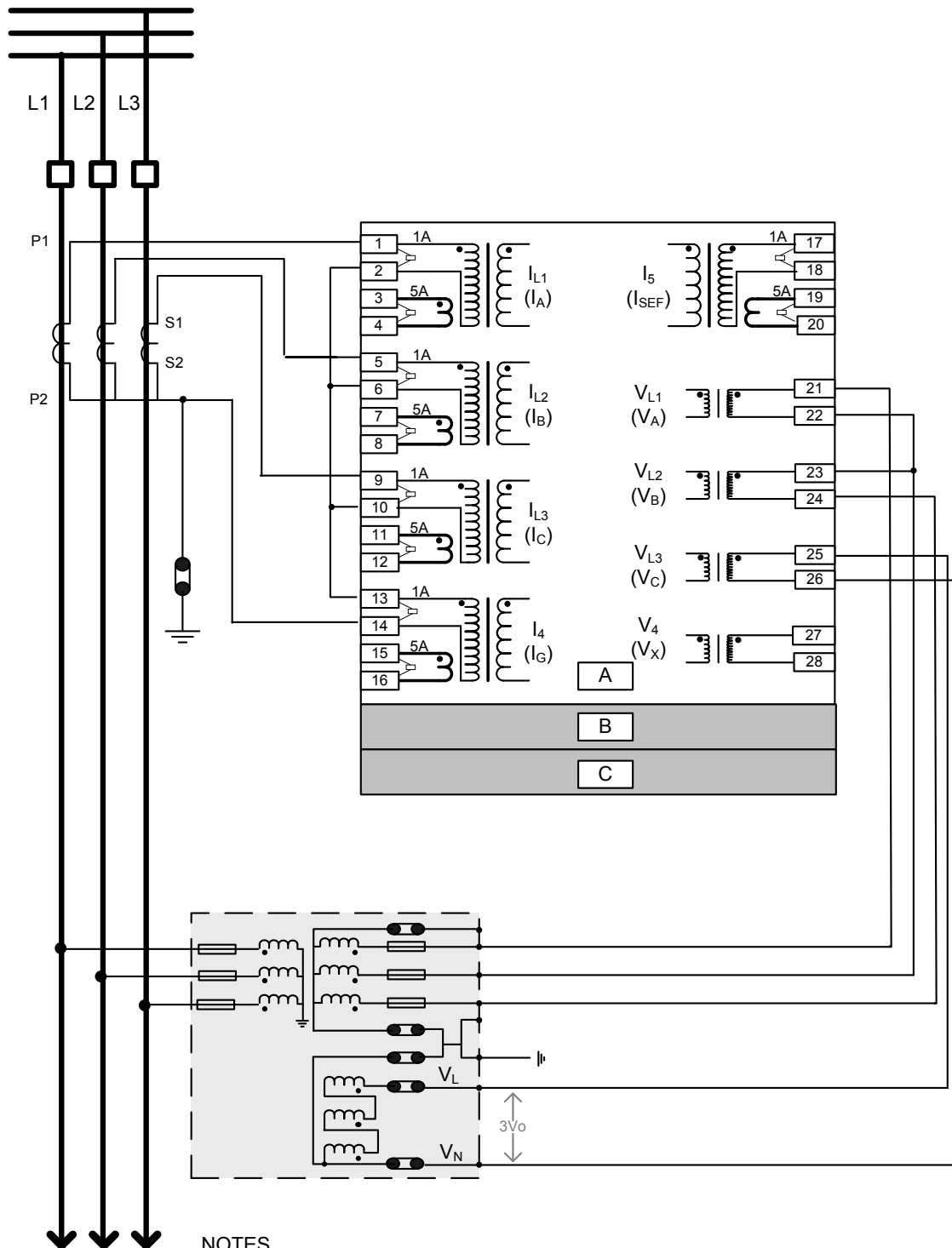

Figure 7.3-1 7SR22 Applied to Feeder Including NVD Protection

## 7.4 Typical Connection: 7SR22 Directional OC/EF and NVD



**NOTES**

- 1) CT circuits are shown connected to 1A tap – use alternative tap for 5A rated CTs.
- 2) CT and Earth connections are typical only.
- 3) Voltage Config:- $V_{ab}$ ,  $V_{bc}$ ,  $3V_0$

**Figure 7.4-1 7SR22 Applied to Feeder**

## 7.5 Typical Connection: 7SR22 Directional OC and EF

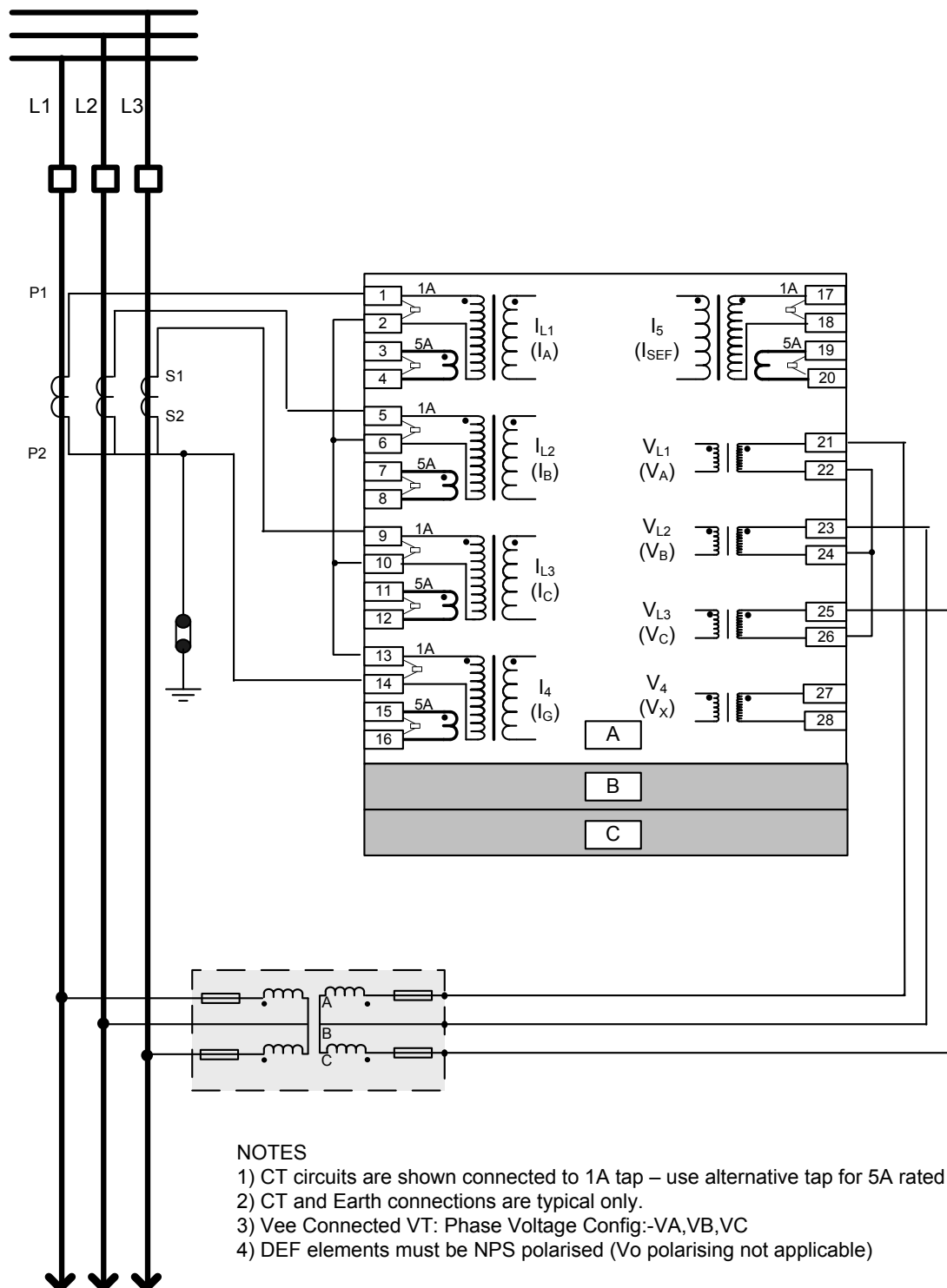
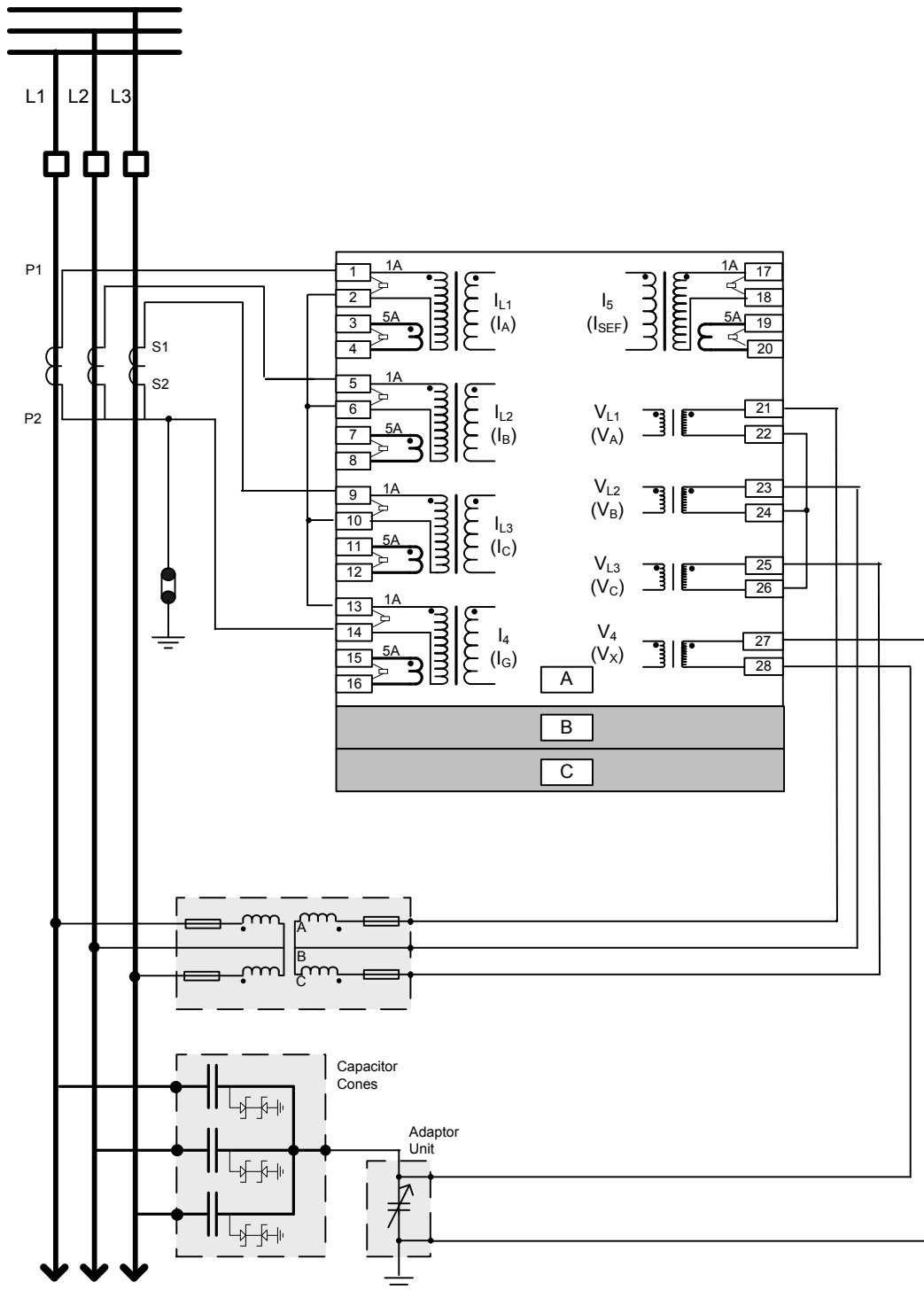

Figure 7.5-1 7SR22 Applied to Feeder - No Zero Sequence Voltage Source

## 7.6 Typical Connection: 7SR22 Connected to VTs and Capacitor Cone Unit



### NOTES

- 1) CT circuits are shown connected to 1A tap – use alternative tap for 5A rated CTs.
- 2) CT and Earth connections are typical only.
- 3) Vee Connected VT: Phase Voltage Config:- $V_A, V_B, V_C$
- 4) DEF elements must be NPS polarised ( $V_0$  polarising not applicable)
- 5)  $V_4$  used for NVD input

Figure 7.6-1 7SR22 Applied to Feeder with Capacitor Cones Fitted